

# LINEAR SHOCK ABSORBER

## CIL3095 - CIL30120

### 1. Description

The linear shock absorber CIL3095-CIL30120 reduces the speed of the door during the final stretch of the trajectory, avoiding slamming and personal injury. The speed can be regulated according to the installation requirement. The shock absorber is charged automatically by the neodymium magnet each time the door opens, and is then ready operate and damp the speed during the consequent closing cycle.

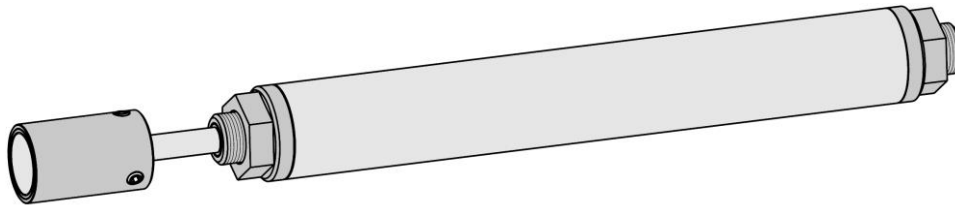

Fig.1

### 2. Dimensions and technical characteristics.

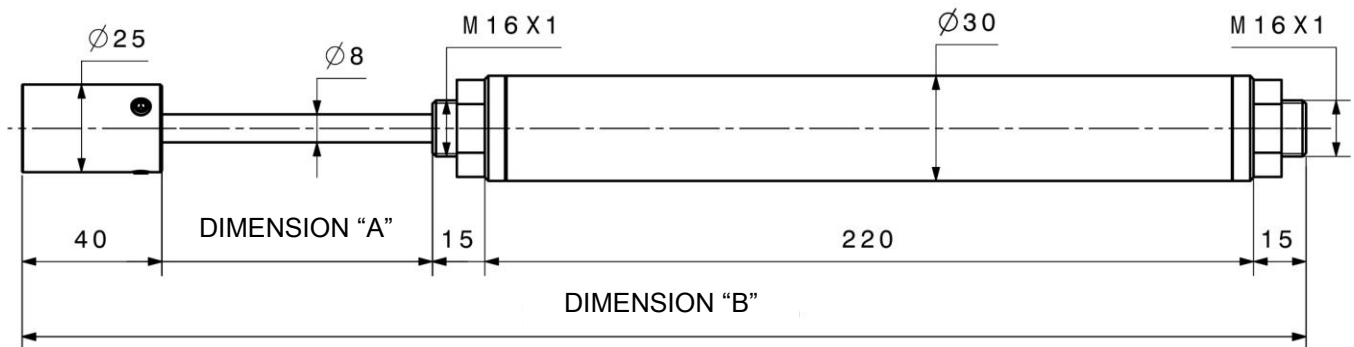

Fig.2

Technical Characteristics	SHOCK ABSORBER 3095	SHOCK ABSORBER 30120
MAXIMUM WIRGHT OF THE DOOR	3000Kg	
MAXIMUM SHOCK ABSORBING FORCE	2600N	3100N
REVERSE MOVEMENT FORCE	30N	
MAXIMUM SPEED OF THE DOOR	0,2m/s	0,2m/s
SERVICE TEMPERATURE	-15°C +70°C	
SHOCK ABSORBER LIMIT SWITCH (A)	95mm	120mm
TOTAL LENGTH (B)	385mm	410mm
LOAD ADJUSTMENT	YES	

### 3. Installation and settings of the shock absorber.

The shock absorber must be positioned on the edge of the door, parallel to the impact force. (Fig.3)

The shock absorber is regulated with the stem in fully extended position the damping force can be regulated by turning the piston as follows:

- Clockwise, will decrease the cushioning. (Fig.4)
- Anti-clockwise, will increase the cushioning. (Fig.5)

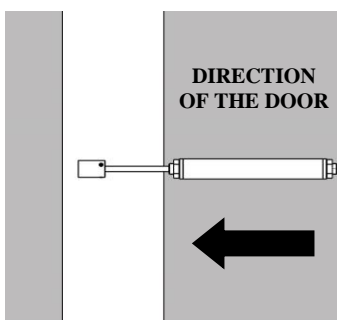

Fig.3

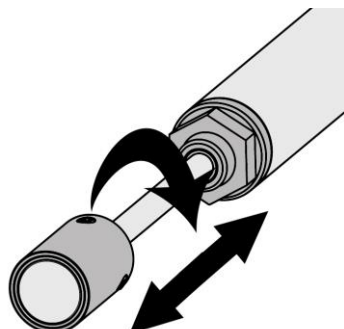

Fig.4

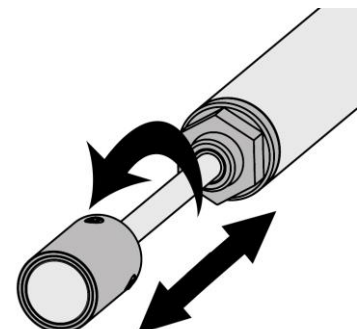

Fig.5



# Declaration of Conformity

Company Name: **Medva Mecanismos del Valles, S.L.**

Address: **C/ Natación 26-28 Pol. Ind. Can Roses - 08191 Rubí**

National Identity Number (CIF/NIF): **B-60528015**

## C E R T I F I E S:

That the hydraulic **CIL 3095/ CIL 30120** has been built to be incorporated into a machine or to be assembled with other machinery to produce a machine in accordance with Directive 2006/42/CE:

Meets the essential safety requirements of the following CEE directives

It also states that it is not allowed to operate machinery until the machine to be incorporated or be a component which has been identified and has been declared under the terms of Directive 2006/42/EC and subsequent changes.

We put the machine of conformity the mark



**Registration Number:** \_\_\_\_\_

Rubí, 22 July 2011

**Company representative**

A handwritten signature in black ink, appearing to be 'A. Orantes Zambrano', written in a cursive style.

**ANTONIO ORANTES ZAMBRANO**