

PASS N

DEA[®]

move as you like

- IT **Barriera veicolare elettromeccanica**
Istruzioni d'uso ed avvertenze
- EN **Electromechanical vehicular barrier**
Operating instructions and warnings
- FR **Barrière électromécanique**
Notice d'emploi et avertissements
- DE **Elektromechanische Schranke**
Bedienungsanleitung und Hinweise
- ES **Barrera electromecánica para vehículos**
Instrucciones de uso y advertencias
- PT **Barreira Electromecânica veicular**
Instruções para utilização e advertências
- PL **Zapora elektromechaniczna blokująca ruch pojazdów**
Instrukcja montażu i użytkowania

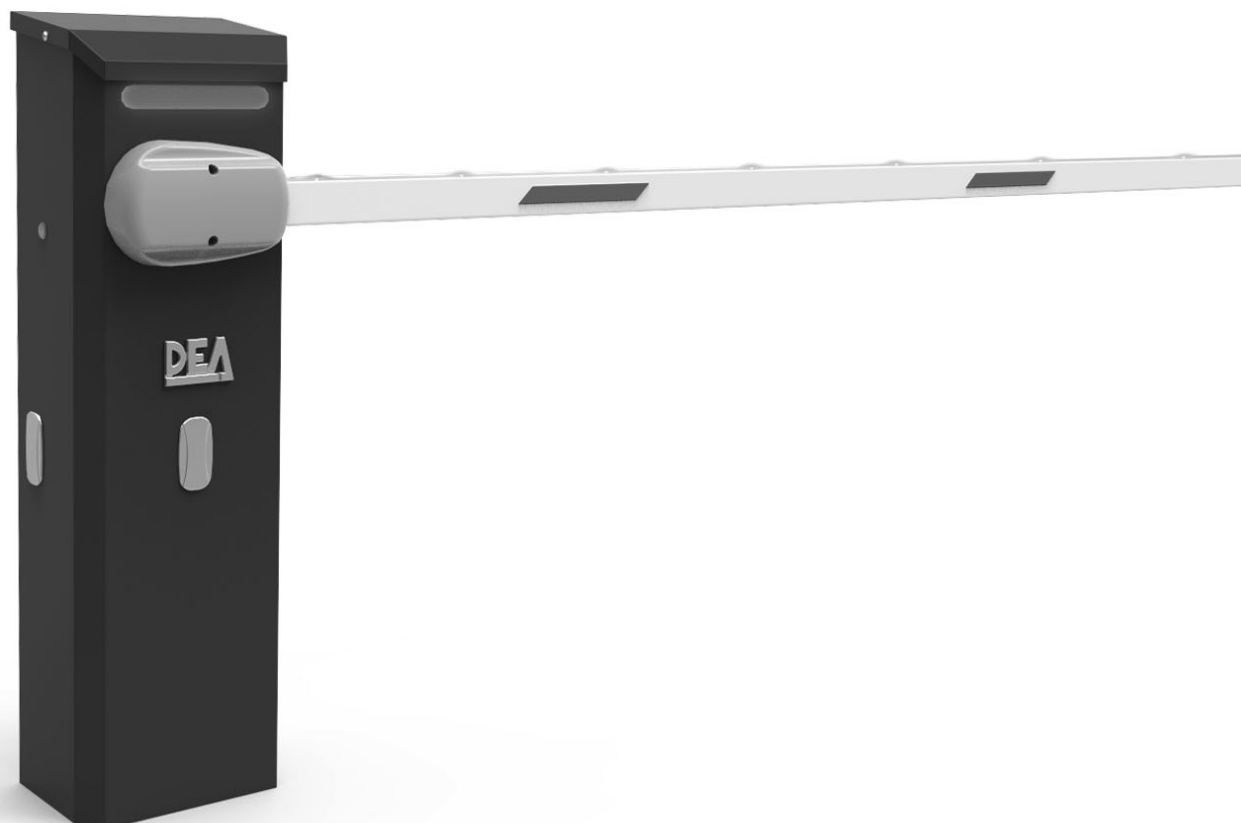
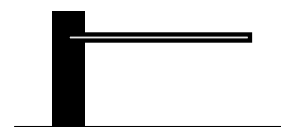

PASS N

Electromechanical vehicular barrier Operating instructions and warnings

Index

1	Warnings Summary	EN-1	6	Start-up	EN-7
2	Product Description	EN-3	6.1	Installation Test	EN-7
3	Technical data	EN-3	6.2	Unlocking and manual operation	EN-7
4	Installation and Assembly	EN-4	7	Maintenance	EN-7
5	Electrical Connections	EN-5	8	Product Disposal	EN-8

1 WARNINGS SUMMARY

WARNING! IMPORTANT SAFETY INSTRUCTIONS. CAREFULLY READ AND FOLLOW ALL WARNINGS AND INSTRUCTIONS THAT ACCOMPANY THE PRODUCT SINCE INCORRECT INSTALLATION COULD CAUSE HARM TO PEOPLE, ANIMALS OR THINGS. WARNINGS AND INSTRUCTIONS PROVIDE IMPORTANT INFORMATION REGARDING SAFETY, INSTALLATION, USE AND MAINTENANCE. KEEP THE INSTRUCTIONS TOGETHER THE TECHNICAL DOCUMENTATION AND FOR FUTURE REFERENCE.

⚠ **WARNING** The device may be used by children of less than 8 years of age, people with reduced physical, mental or sensory impairment, or generally anyone without experience or, in any case, the required experience provided the device is used under surveillance or that users have received proper training on safe use of the device and are aware of the dangers related to its use.

⚠ **WARNING** Do not allow children to play with the device, the fixed commands or the radio controls of the system.

⚠ **WARNING** Product use in abnormal conditions not foreseen by the manufacturer may generate hazardous situations; meet the conditions indicated in these instructions.

⚠ **WARNING DEA** System reminds all users that the selection, positioning and installation of all materials and devices which make up the complete automation system, must comply with the European Directives 2006/42/CE (Machinery Directive), 2014/53/UE (RED Directive). In order to ensure a suitable level of safety, besides complying with local regulations, it is advisable to comply also with the above mentioned Directives in all extra European countries.

⚠ **WARNING** Under no circumstances use the device in an explosive atmosphere or in areas that may be corrosive or could damage product parts. Check that the temperatures at the installation site are suitable and comply with the temperatures declared on the product label.

⚠ **WARNING** When working with the “dead man” switch, make sure that there are no people in the area where the automatism is being used.

⚠ **WARNING** Check that there is a switch or an omni polar magneto-thermal circuit breaker that enables complete disconnection in case of over voltage category III conditions installed upstream from the power system.

⚠ **WARNING** To ensure an appropriate level of electrical safety always keep the 230V power supply cables apart (minimum 4mm in the open or 1 mm through insulation) from low voltage cables (motors power supply, controls, electric locks, aerial and auxiliary circuits power supply), and fasten the latter with appropriate clamps near the terminal boards.

⚠ **WARNING** If the power cable is damaged, it must be replaced by the manufacturer or its technical assistance service or, in any case, by a person with similar qualifications to prevent any risk.

⚠ **WARNING** All installation, maintenance, cleaning or repair operations on any part of the system must be performed exclusively by qualified personnel with the power supply disconnected working in strict compliance with the electrical standards and regulations in force in the nation of installation.

Cleaning and maintenance destined to be performed by the user must not be performed by unsupervised children.

⚠ **WARNING** Using spare parts not indicated by **DEA** System and/or incorrect re-assembly can create risk to people, animals and property and also damage the product. For this reason, always use only the parts indicated by **DEA** System and scrupulously follow all assembly instructions.

⚠ **WARNING** Changing the closing intensity could lead to dangerous situations. Therefore, qualified personnel should only perform increases to the closing force. After adjustment, compliance with regulatory limits values should be detected with a force impact-measuring instrument. The sensitivity of the obstacle detection may be adjusted gradually to the door (see programming instructions). The anti-crushing device operation must be checked after each manual adjustment. Manual modification of the force can only be done by qualified personnel by performing the measurement test according to EN 12445. Modifications to the force adjustment must be documented in the machine manual.

⚠ **WARNING** The compliance of the internal sensing obstacles device to requirements of EN12453 is guaranteed only if used in conjunction with motors fitted with encoders.

⚠ **WARNING** Any external security devices used for compliance with the limits of impact forces must be conform to standard EN12978.

♻ **WARNING** In compliance with EU Directive 2012/19/EU on waste electrical and electronic equipment (WEEE), this electrical product should not be treated as municipal mixed waste. Please dispose of the product and bring it to the collection for an appropriate local municipal recycling.

EVERYTHING THAT IS NOT EXPRESSLY PROVIDED FOR IN THE INSTALLATION MANUAL IS NOT ALLOWED. CORRECT OPERATOR OPERATION IS ONLY ENSUED WHEN THE REPORTED DATA IS RESPECTED. THE COMPANY DOES NOT RESPOND FOR DAMAGE CAUSED BY FAILURE TO COMPLY WITH THE INSTRUCTIONS CONTAINED IN THIS MANUAL. WITHOUT AFFECTING THE ESSENTIAL FEATURES OF THE PRODUCT, THE COMPANY RESERVES THE RIGHT TO MAKE ANY CHANGES DEEMED APPROPRIATE AND AT ANY TIME IN ORDER TO TECHNICALLY, STRUCTURALLY AND COMMERCIALY IMPROVE THE PRODUCT WITHOUT BEING REQUIRED TO UPDATE THIS DOCUMENT.

2 PRODUCT DESCRIPTION

Models and contents of the package

The name PASS N identifies a series of electromechanical barriers with different characteristics with regard to the motor power supply, the speed of movement and the maximum length of the boom. All motorized models foresee the use of advanced control units (NET series) equipped with anti-crush sensor, built-in 433 MHz radio receiver, speed adjustment and slow down during opening and closing.

The PASS N model is intended for residential use or small car parks.

The choice of barrier depends on the width of the access area and the expected duty cycle.

The **DEA** System complementary accessories are indicated in the table "PRODUCT ACCESSORIES" (pag. I-7).

PASS N vehicular barriers are composed by an electromechanical operator which puts in rotation the boom directly, while the balance is assigned to a compression spring.

The automation together with the control panel, is enclosed in a painted sheet metal box (or steel) with a lockable door.

Transport

PASS N is always delivered packed in boxes that provide adequate protection to the product, however, pay attention to all information that may be provided on the same box for storage and handling.

3 TECHNICAL DATA

OPERATOR			
	PASS24NET/N/V	PASS24NET/N/L	PASS24NET/N/VR
Motor power supply voltage (V)	24 V ---		
Absorbed power (W)	105		
Type of boom used	Refer to Table on page I-6		
Duty cycle (cycles/hour)	290	140	240
Maximum n° of operations in 24 hour	800		
Operating temperature range (°C)	-20÷50 °C		
Opening time 90° (s)	2,2 s	6 s	2,8 s
Weight of product with package (Kg)	41		
Sound pressure emitted (dBA)	< 70		
Protection degree	IPX4		
CONTROL BOARD			
NET24N			
Power supply (V)	230 V ~ ±10% (50/60 Hz)		
Rated power transformer (VA)	150 VA (230/22V)		
Fuse F2 (A) (transformer)	2A		
Batteries	2x 12V 4A		
Fuse F1 (A) (batteries input)	15A		
24V operators outputs	2x 5A		
Warning: The above values are calculated by taking the maximum power supplied by the respective processors. In absolute terms, the maximum current from each output must not exceed 10A.			
Auxiliaries power supply output	24 V ---		
Safety devices power supply output	(24V_AUX + 24V_ST = max 200mA)		
"Warning" output	24 V --- max 15 W		
Electric lock output	24V --- max 5W or max 1 art. 110		
Flashing light output	24 V --- max 15W		
Operating temperature range (°C)	-20÷50 °C		
Receiver frequency	433,92 MHz		
Transmitters type of coding	HCS fix-code - HCS rolling code - Dip-switch		
Max remote controllers managed	100		

4 INSTALLATION AND ASSEMBLY

WARNING The barrier must be used exclusively for the passage of vehicles. Prohibit the passage of pedestrians in the manoeuvring area. Provide an appropriately marked pedestrian crossing if necessary.

4.1 For a satisfactory installation of the product is important to:

- Define the project in full of the automatic opening;
- Carefully evaluate the model of barrier to install considering the characteristics of the area, the soil and the type of service requested;
- Define the location of the automation and the necessary accessories;
- Verify that the bulk of the automation is compatible with the area chosen for the installation and the space required for the movement of the rod is sufficient (Pic. 1);
- The power cable must be long enough to allow manual release of the control board.

4.2 Defined and satisfied these prerequisites, proceed to the assembly:

WARNING PASS N barriers are always supplied right hand side, (which means that opening the door of the box the bar is left and can be opened in a clockwise direction).

WARNING When working on the spring, to remove or balance it, there is a danger of injury to hands from moving parts. Please be careful! Perform these operations when the spring is discharged (barrier opened).

PASS N can be fixed to the ground in two ways:

By anchor bolts (not supplied)

- Verify that the site is prepared for the installation of the barrier and that there is an adequate number of channels for the passage of electric cables;
- Secure the barrier using appropriate anchors (expansion or chemical).

By a foundation plate (Art. PASS/B) (Pic. 2)

- Dig a hole suitable for the type of soil;
- Provide an adequate number of channels for the passage of electric cables;
- Place the plate of the foundation at about 20mm from the floor;
- Cement the excavation, with a spirit level check the position of the plate and wait for the concrete to solidify;
- Secure the barrier to the foundation base and lock it with M12 nuts (not supplied).

4.3 How to unlock the operator (Pic. 3)

All PASS N models have an unlocking system; the working of this system is the following:

Disconnect power supply from the barrier. To unlock the barrier, you just turn the lock on the side of the body (clockwise to unlock and counterclockwise to relock).

Check the release occurred, ensuring that the movement of the boom is free.

4.4 How to mount the operator left

WARNING All balancing operations must be performed with factory operator configuration and the control panel turned off.

Before starting to mount the boom, check the boom length accordingly to the width of the opening and, if necessary, cut it by using proper equipment.

WARNING For safety purposes, **DEA** system recommends that two people carry out the operation. This can avoid dangerous situations and to operate even under unfavourable conditions (e.g. in the presence of strong wind, sloping ground, etc.). Please note that accidentally dropping the rod during assembly can cause serious damage to the mechanics of the barrier.

Proceed as described:

- Loosen the nut and loosen the tensioner to release all spring tension (Pic. 4);
- Unscrew and remove the lower fixing screw of the spring unit (Pic. 5);
- Unscrew the superior fixing screw of the spring assembly and remove it (Pic. 6);
- Mount the boom horizontally (Pic. 7);
- Unlock the operator;
- Lift the boom and at around 45°, **re-lock the operator**;
- Bring the boom to the complete open position (Fig. 8) until the lock key falls into place (Pic. 9);
- **WARNING: When lifting, the boom is uncontrolled and if dropped it may cause serious damage to the mechanics.**
- Reassemble the spring unit on the left side of the box (Pic. 10) following what is indicated in the balancing table as regards the choice of the fixing hole.
- Balance the boom ensuring that at about 45° it doesn't perform any uncontrolled movement (otherwise act on the tensioner). Next, tighten the nut (Pic. 15).

4.5 How to mount the boom

WARNING All balancing operations must be performed with factory operator configuration and the control panel turned off.

Before starting to mount the boom, check the boom length accordingly to the width of the opening and, if necessary, cut it by using proper equipment.

WARNING For safety purposes, **DEA** system recommends that two people carry out the operation. This can avoid dangerous situations and to operate even under unfavourable conditions (e.g. in the presence of strong wind, sloping ground, etc.). Please note that accidentally dropping the rod during assembly can cause serious damage to the mechanics of the barrier.

Then proceed as follows:

- Ensure that the boom-holder is positioned vertically (springs fully discharged);
- Unscrew and remove the lower fixing screw of the spring unit (Pic. 5);
- Unlock the operator;
- Rotate the boom-holder 90° clockwise and lock the operator in this position (Pic. 11);
- Mounting the boom in a horizontal position (Pic. 12);
- Unlock the operator;
- Lift the boom and at around 45°, **re-lock the operator**;
- Bring the boom to the complete open position (Pic. 13) until the lock key falls into place (Pic. 14);
- **WARNING: When lifting, the boom is uncontrolled and if dropped it may cause serious damage to the mechanics.**
- Refit the lower fixing screw of the spring unit;
- Perform a balancing test by verifying that moving the boom to 45°, and letting go, it should balance uncontrolled movements (otherwise adjust). Next, tighten the nut (Pic. 15);
- Fit the cover of the boom-holder.

4.6 Limit-switches (Pic. 16)

All PASS N models are equipped with mechanical stops which allow the adjustment of the boom run while closing and opening. Release the operator and adjust the mechanical stops by loosening the lock nut (A) and then adjust the hexagonal head screw (B). Then tighten the lock nut (A).

5 ELECTRICAL CONNECTIONS

In case you have to operate on the control panel (for wiring, adjustments etc...), remove the circuit support plate. To do this, proceed as follows (Pic. 17):

- unscrew the fixing screws of the control panel holder plate, without removing them;
- Unhook the plate of the barrier case as shown;
- Move the control panel box into a most comfortable position and perform the necessary tasks;

Run the motor connections following the wiring diagrams.

WARNING For adequate electrical safety, keep low safety voltage wires (controls, electro-locks, antenna, auxiliary power) clearly separate from 230V ~ power wires (**minimum 4 mm in air or 1 mm via supplementary insulation**) placing them in plastic raceways and securing them with adequate clamps near terminal boards.

WARNING For connection to the mains, use a multipolar cable having a minimum section 3x1,5 mm² and complying with the current regulations. For connecting the motors, use a minimum cross section 1,5 mm² cable and complying with the current regulations. As an example, if the cable is outside (outdoor), must be at least equal to H05RN-F, whereas if it (in a raceway), must be at least equal to H05VV-F.

WARNING All wires must be striped and unsheathed in the immediate vicinity of terminals. Keep wires slightly longer to subsequently eliminate any excess.

WARNING Maintain the ground conductor at a major length respect the active conductors so that, if the cable exit from its fixing housing, the active conductors tighten up as first.

WARNING To connect the encoder to the control panel, use only a dedicated cable 3x0,75mm².

Program the control board to complete all adjustments. It is now possible to supply a complete installation in compliance with all standards required for gate automation. **See the instructions provided with the control panel to be connected.**

Finally, verify that all adjustments operations have been correctly performed and that safety devices and unlocking device properly work.

Recommended values for standard "TYPE 03 - Barriers" 24V						
	Running speed (P032 - P033)	Slowdown speed (P031 - P034)	Slowdown duration (P035 - P036)	Soft start (P054)	Facilitation release (P057)	Stop margin (P058 - P059)
PASS24NET/N/L (4/5 m)	100%	30%	15%	0	2	10
PASS24NET/N/V (3 m)	80%	25%	45%	0	1	3
PASS24NET/N/VR (4 m)	80%	25%	45%	0	1	3

WIRING DIAGRAM FOR 24V

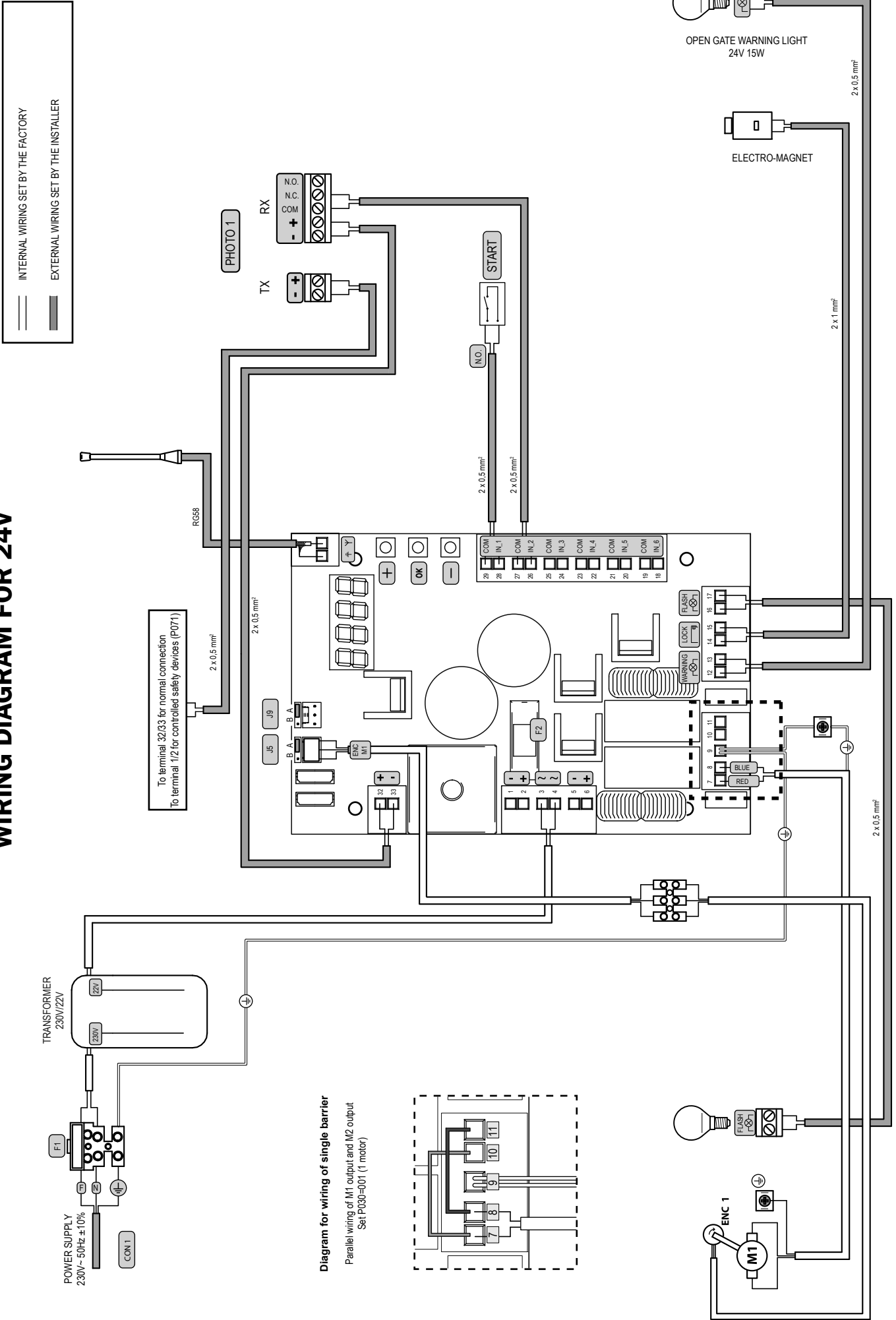

INTERNAL WIRING SET BY THE FACTORY
EXTERNAL WIRING SET BY THE INSTALLER

To terminal 32/33 for normal connection
To terminal 1/2 for controlled safety devices (P071)

Diagram for wiring of single barrier
Parallel wiring of M1 output and M2 output
Set P030=001 (1 motor)

6 START-UP

The start-up phase is very important to ensure maximum security and compliance to regulations, including all the requirements of EN 12445 standard which establishes the test methods for testing the automation for gates.

DEA System reminds that all installation, maintenance, cleaning or repair operations on any part of the system must be performed exclusively by qualified personnel who must be responsible of all texts require by the eventual risk;

6.1 Installation test

The testing operation is essential in order to verify the correct installation of the system. **DEA System** wants to summarize the proper testing of all the automation in 4 easy steps:

- Make sure that you comply strictly as described in paragraph 2 "WARNINGS SUMMARY";
- Test the opening and closing making sure that the movement of the boom is as expected.
We suggest in this regard to perform various tests to assess the smoothness of the gate and defects in assembly or adjustment;
- Ensure that all safety devices connected work properly;
- Perform the measurement of impact forces in accordance with the standard 12445 to find the setting that ensures compliance with the limits set by the standard EN12453.

WARNING Using spare parts not indicated by **DEA System** and/or incorrect re-assembly can create a risk to people, animals and property and also damage the product. For this reason, always use only the parts indicated by **DEA System** and scrupulously follow all assembly instructions.

6.2 Unlocking and Manual operation

In the event of malfunctions or simple power failure, release the motor (Pic. 3) and perform the manual operation of the boom.

The knowledge of the unlocking operation is very important, because in times of emergency the lack of timeliness in acting on such a device can be dangerous.

WARNING The efficacy and safety of manual operation of the automation is guaranteed by **DEA System** only if the installation has been installed correctly and with original accessories.

WARNING Avoid any intervention in the presence of voltage. Opening the door of the box presents a danger of injury to the hands, hold the boom to prevent dangerous movements of the internal mechanisms.

7 MAINTENANCE

Good preventive maintenance and regular inspection ensure long working life. In the table below you will find a list of inspections/maintenance operations to be programmed and executed periodically.

Consult the TROUBLE-SHOOTING" table whenever anomalies are observed in order to find the solution to the problem and contact **DEA System** directly whenever the solution required is not provided.

INTERVENTION TYPE	PERIODICITY
cleaning of external surfaces	6 months
checking of screw tightening	6 months
checking of release mechanism operation	6 months
greasing of articulated joint	1 year
Checking of boom balancing	1 year

TROUBLE-SHOOTING	
Description	Possible solutions
When the opening command is given, the barrier doesn't move and the electrical motor doesn't work.	The operator is not receiving correct power supply. Check all connections, fuses and the power supply cable conditions and replace or repair if necessary.
When the opening command is given, the motor starts but the boom fails to move.	Check that the unlocking system is closed. Check that the electronic device for the force adjust is in good conditions.
The barrier doesn't perfectly stop in vertical or horizontal position or pushes the supports.	Check the boom balancing.
The barrier doesn't perfectly stop in vertical or horizontal position or pushes the supports.	Adjust the mechanical limit switches.

8 PRODUCT DISPOSAL

PASS N consists of materials of various types, some of which can be recycled (electrical cables, plastic, aluminum, etc. ...) while others must be disposed of (electronic boards and components).

Proceed as follows:

1. Disconnect the barrier from power supply and completely discharge the spring;
2. Disconnect and disassemble all the accessories connected. Follow the instructions in reverse to that described in the section "Installation";
3. Remove the electronic components;
4. Sorting and disposing of the materials exactly as per the regulations in the country of sale.



WARNING In line with EU Directive 2012/19/EU for waste electrical and electronic equipment (WEEE), this electrical product must not be disposed of as unsorted municipal waste. Please dispose of this product by returning it to your local municipal collection point for recycling.

Esempio di installazione tipica - Example of typical installation - Exemple d'installation typique - Installationsbeispiel - Ejemplo de instalación típica - Exemplo de instalação típica - Przykład standardowego systemu automatyzacji

DEA System fornisce queste indicazioni che si possono ritenere valide per un impianto tipo ma che non possono essere complete. Per ogni automatismo, infatti, l'installatore deve valutare attentamente le reali condizioni del posto ed i requisiti dell'installazione in termini di prestazioni e di sicurezza; sarà in base a queste considerazioni che redigerà l'analisi dei rischi e progetterà nel dettaglio l'automatismo. - DEA System provides the following instructions which are valid for a typical system but obviously not complete for every system. For each automatism the installer must carefully evaluate the real conditions existing at the site. The installation requisites in terms of both performance and safety must be based upon such considerations, which will also form the basis for the risk analysis and the detailed design of the automatism. - DEA System fournit ces indications que vous pouvez considérer comme valables pour une installation-type, même si elles ne peuvent pas être complètes. En effet, pour chaque automatisation, l'installateur doit évaluer attentivement les conditions réelles du site et les prérequis de l'installation au point de vue performances et sécurité ; c'est sur la base de ces considérations qu'il rédigera l'analyse des risques et qu'il concevra l'automatisation d'une manière détaillée. - Diese Angaben von DEA System können als gültig für eine Standardanlage angesehen werden, können aber nicht erschöpfend sein. So muss der Installationsfachmann für jedes Automatiksystem sorgfältig die Voraussetzungen des Installationsortes sowie die Leistungs- und

Sicherheitsanforderungen an die Installation abwägen; aufgrund dieser Überlegungen muss er die Risikobewertung erstellen und genau das Automatiksystem entwickeln. - DEA System facilita estas indicaciones que pueden considerarse válidas para una instalación tipo pero que no pueden considerarse completas. El instalador, en efecto, tiene que evaluar atentamente para cada automatismo las reales condiciones del sitio y los requisitos de la instalación por lo que se refiere a prestaciones y seguridad; en función de estas consideraciones redactará el análisis de riesgos y efectuará el proyecto detallado del automatismo. - DEA System fornece estas indicações que podem ser consideradas válidas para o equipamento padrão, mas que podem não ser completas. Para cada automatismo praticamente o técnico de instalação deverá avaliar com atenção as condições reais do sítio e os requisitos da instalação em termos de performance e de segurança; será em função destas considerações que realizará uma análise dos riscos e projectará. - DEA System dostarcza wskazówek, do wykorzystania w typowej instalacji ale nie będą one nigdy kompletne. Dla każdego typu automatyki, instalator musi sam oszacować realne warunki miejsca montażu i wymogi instalacyjne mając na uwadze przepisy dotyczące bezpieczeństwa. Na podstawie zebranych informacji będzie w stanie przeanalizować zagrożenia mogące wystąpić i zaprojektować w szczególności automatyzację.

Pos.	Descrizione - Description - Description - Beschreibung - Descripción - Descrição - Opis
1	PASS N
2	Lampeggiante - Flashing light - Clignotant - Blinker - Lámpara - Intermitente - Lampa Ostrzegawcza
3	Fotocellule - Photocells - Photocellules - Fotozellen - Fotocélulas - Fotocélulas - Fotokomórki
4	Selettore a chiave antiscasso - Anti lock-picking key switch - Sélecteur à clé anti-intrusion - Einbruchfester Schlüsselschalter - Selector a llave antisabotaje - Interruptor de chave burglar - Przełącznik kluczowy wandaloodporny
5	Radiocomando - Remote-control - Radiocommande - Funksteuerung - Radiocomando - Comando via rádio - Nadajnik
6	Colonnina Pilly 60 - Pilly 60 column - Colonnnette Pilly 60 - Kleine Säule Pilly 60 - Columna Pilly 60 - Coluna Pilly 60 - Kolumnienka Pilly 60

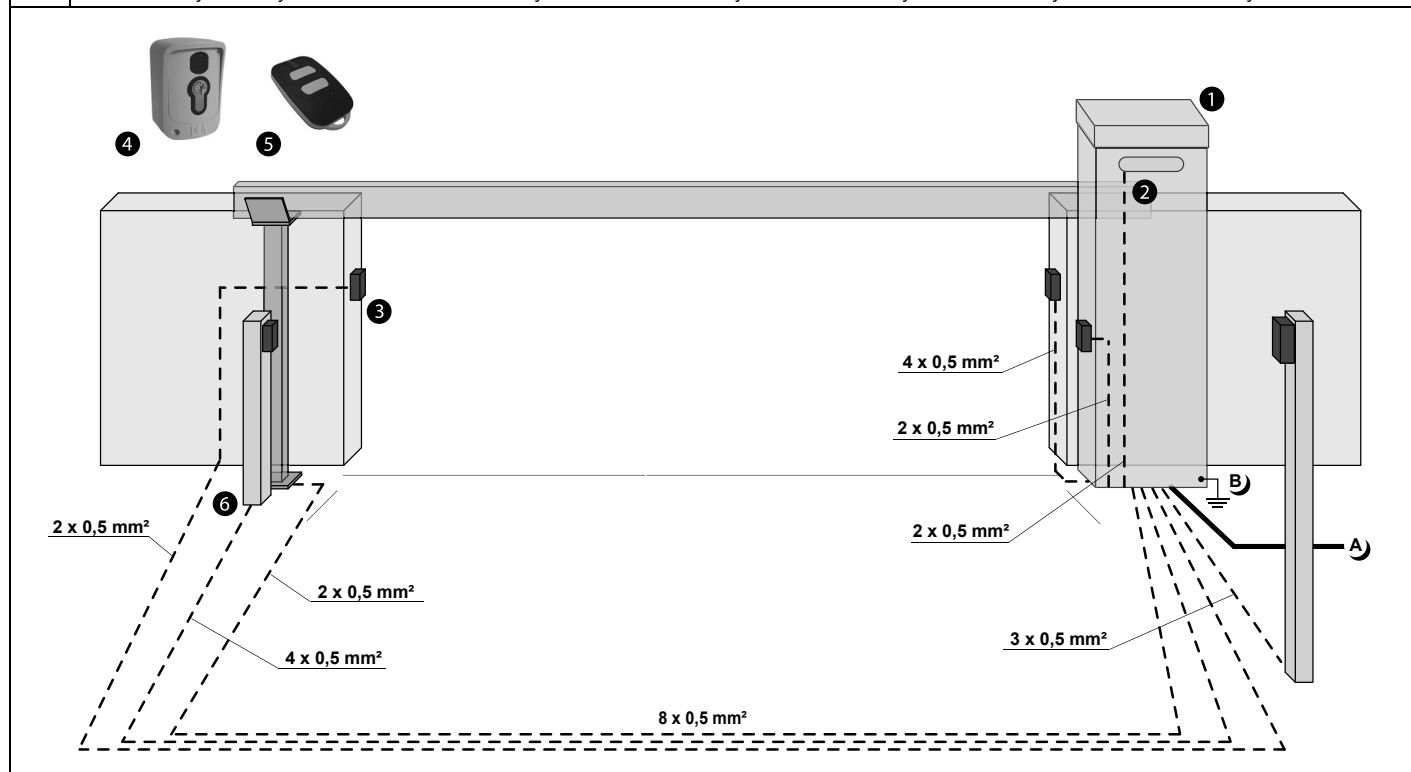

- A) Collegarsi alla rete 230V ~ ± 10% 50/60 Hz tramite un interruttore onnipolare o altro dispositivo che assicuri la onnipolare disinserzione della rete, con una distanza di apertura dei contatti ≥ 3 mm - Make the 230V ~ ±10% 50/60 Hz mains connection using an omnipolar switch or any other device that guarantees the omnipolar disconnection of the mains network with a contact opening distance of 3 mm - Connectez-vous au réseau 230V ~ ±10% 50/60 Hz au moyen d'un interrupteur onnipolaire ou d'un autre dispositif qui assure le débranchement onnipolaire du réseau, avec un écartement des contacts égal à 3 mm. - Den Anschluss an das 230V ~ ±10% 50/60 Hz Netz mit einem Allpolschalter oder einer anderen Vorrichtung vornehmen, durch die eine allpolige Netzunterbrechung bei einem Öffnungsabstand der Kontakte von ≥ 3 mm gewährleistet wird. - Efectuar la conexión a una línea eléctrica 230V ~ ±10% 50/60 Hz a través de un interruptor omnipolar u otro dispositivo que asegure la omnipolar desconexión de la línea, con 3 mm de distancia de abertura de los contactos. - Ligue na rede de 230V ~ ±10% 50/60 Hz mediante um interruptor omnipolar ou outro dispositivo que assegure que se desliga de maneira omnipolar da rede, com abertura dos contactos de pelo menos 3 mm de distância - Podłączyć się do sieci 230V ~ ±10% 50/60 Hz poprzez przełącznik jednobiegunowy lub inne urządzenie które zapewni brak zakłóceń w sieci, przy odległości między stykami ≥ 3 mm.**
- B) Collegare a terra tutte le masse metalliche - All metal parts must be grounded - Connectez toutes les masses métalliques à la terre - Alle Metallteile erden - Conectar con la tierra todas las masas metálicas - Realize ligação à terra de todas as massas metálicas - Uziemić wszystkie elementy metalowe.**

1



2

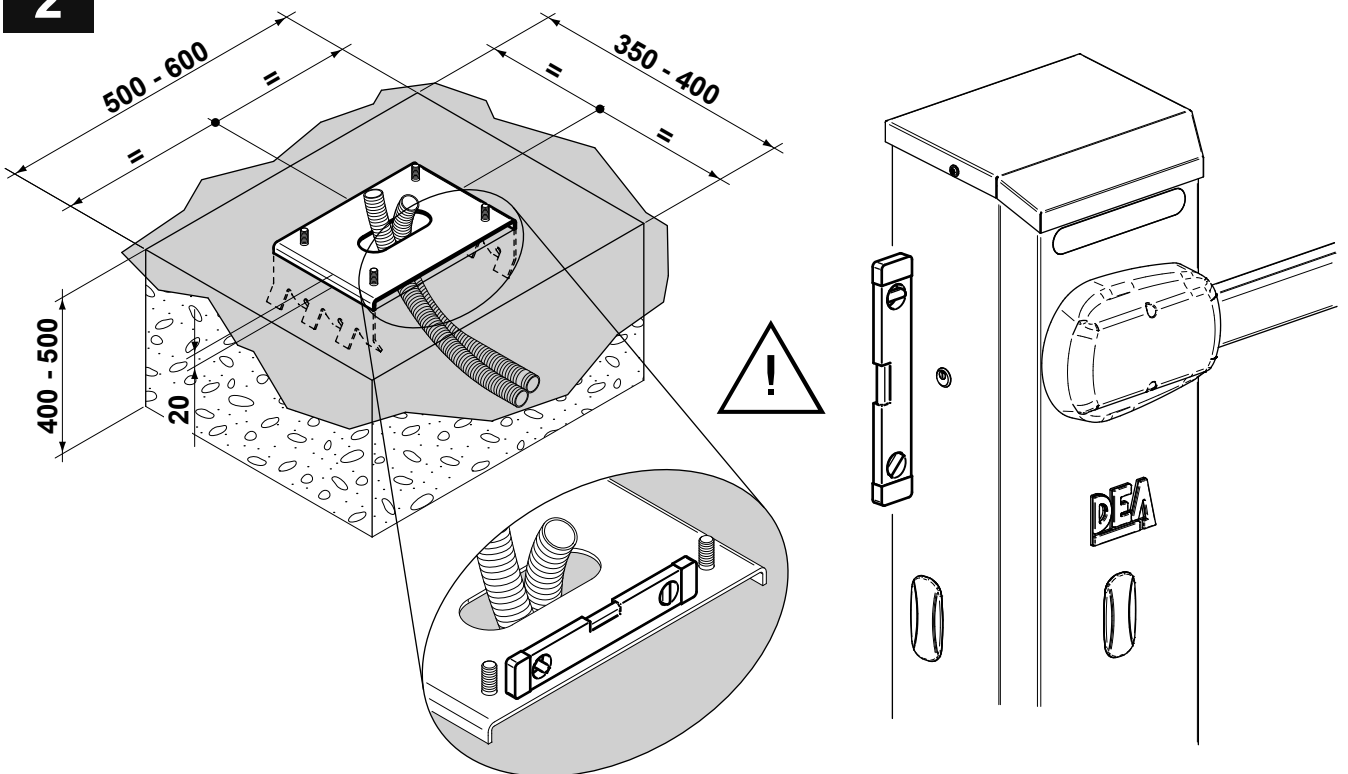

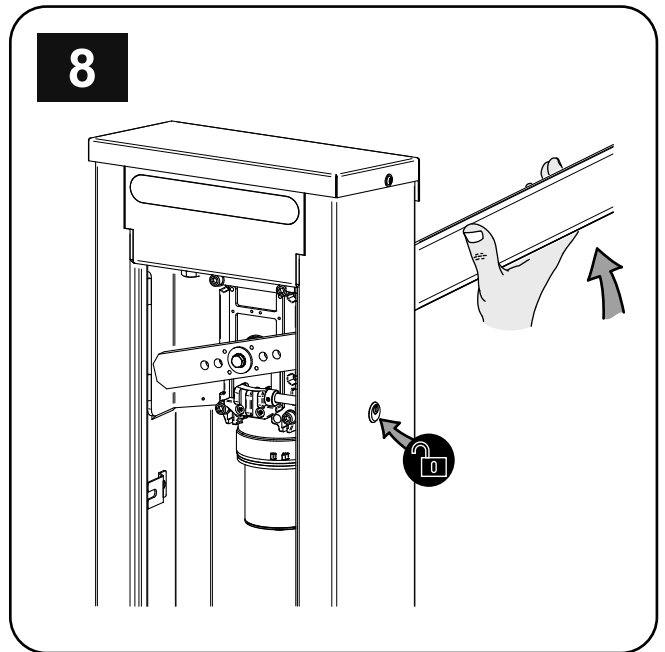
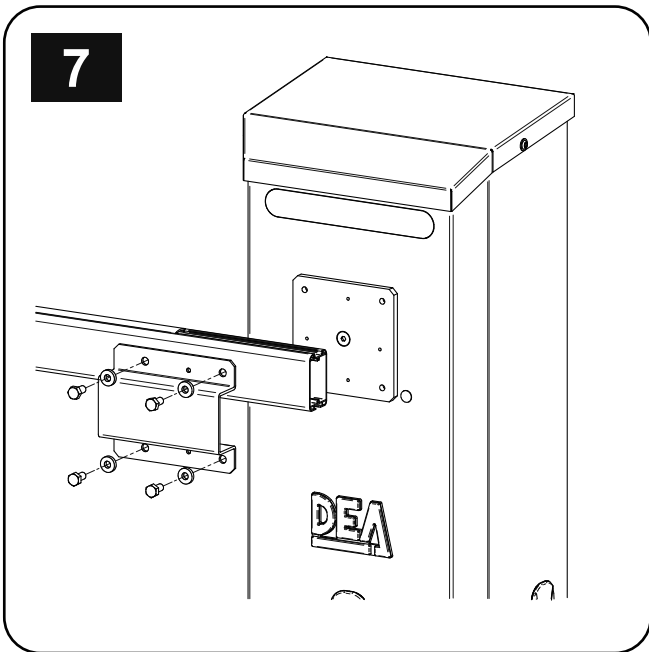
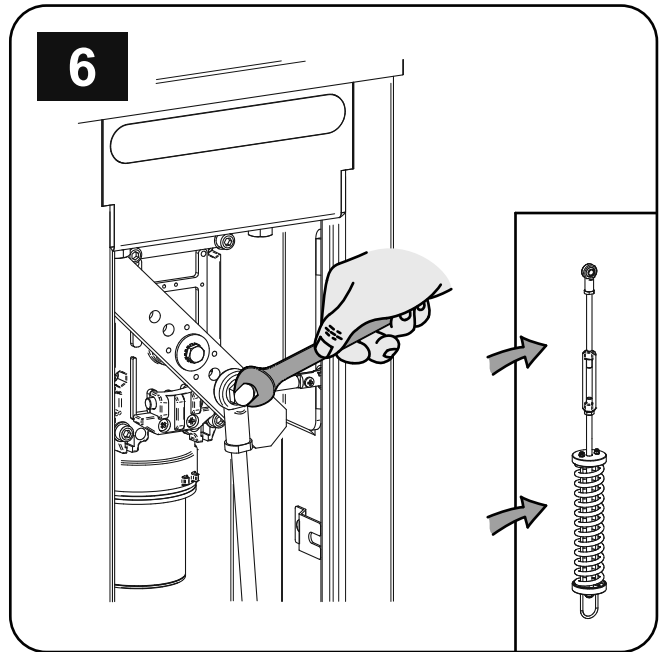
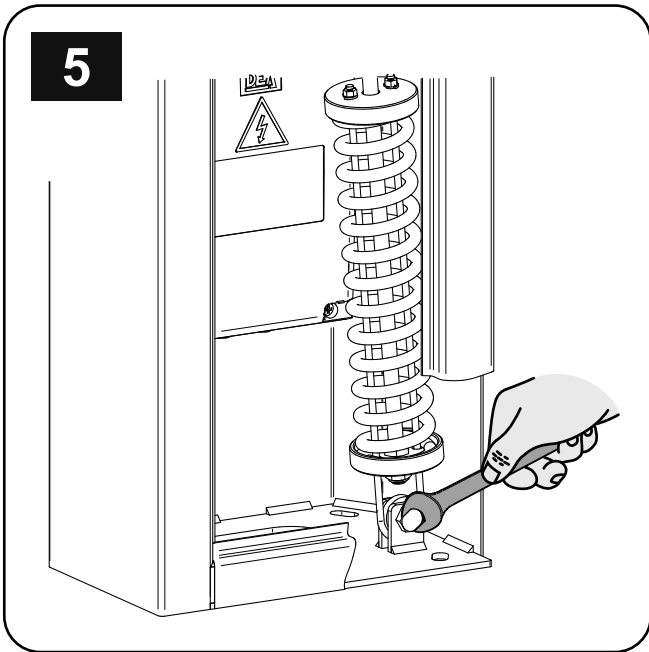
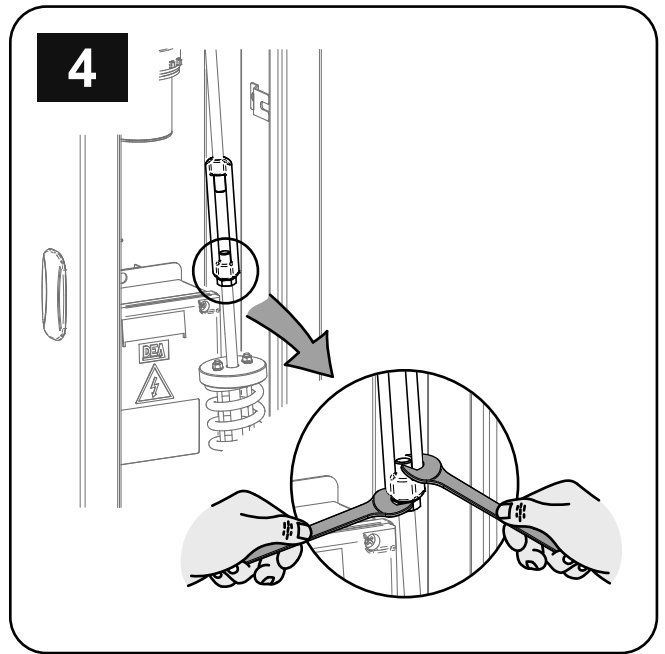
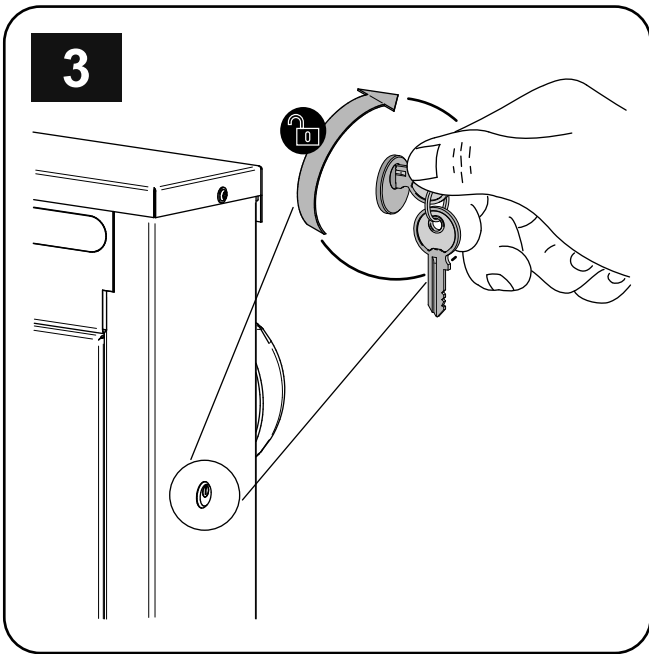

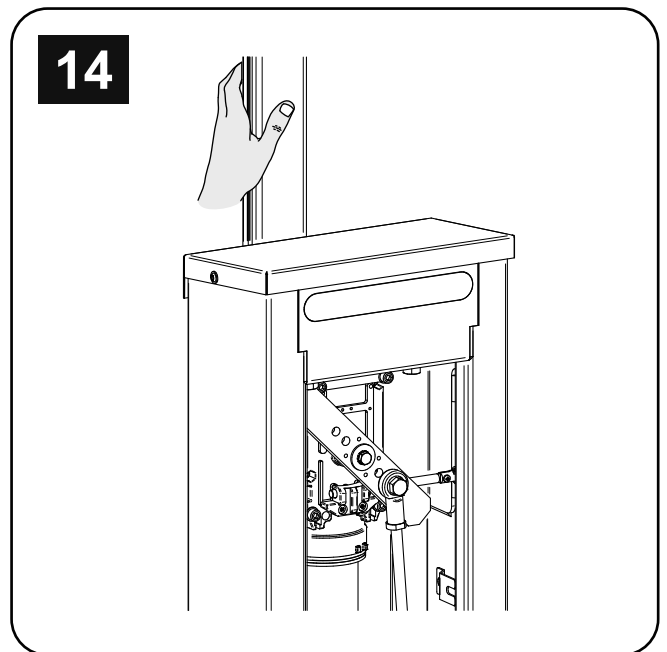
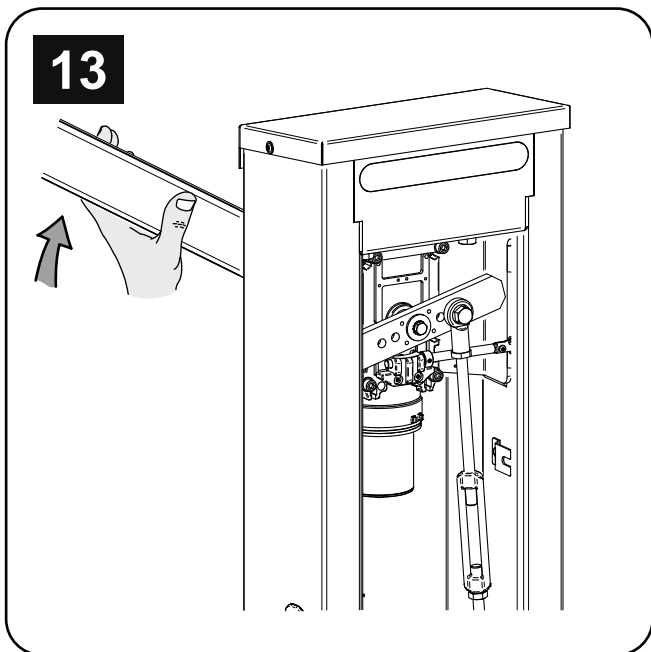
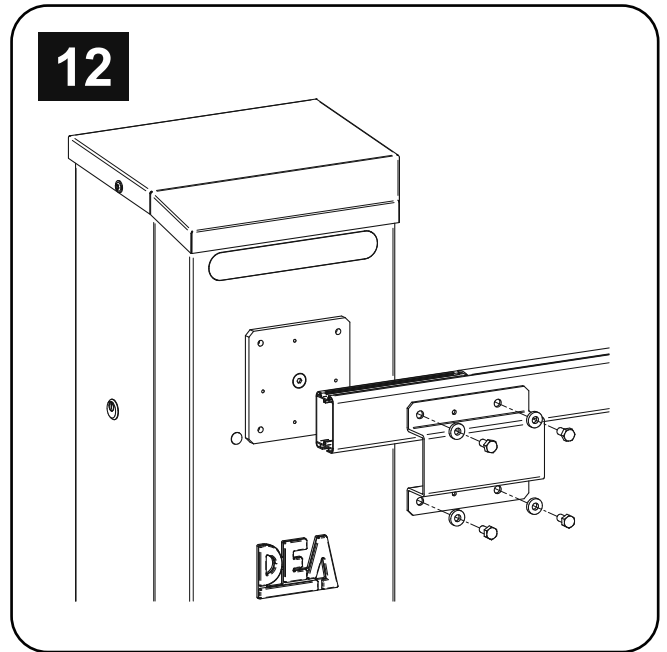
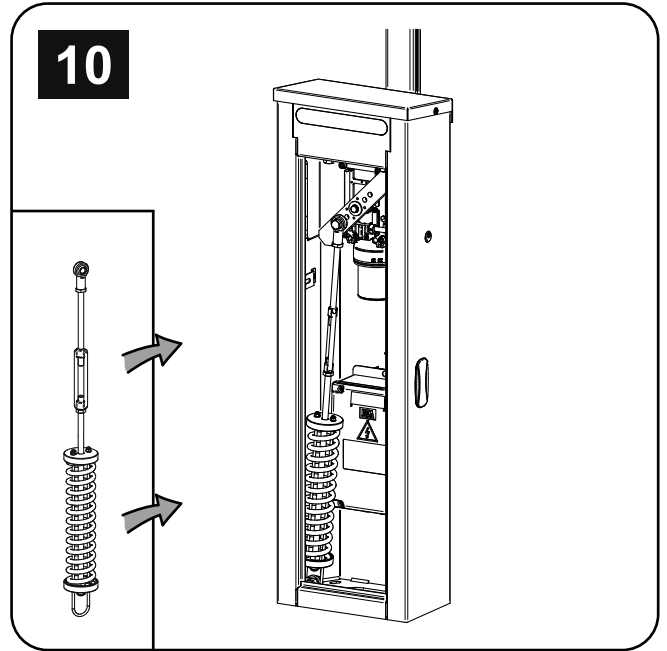
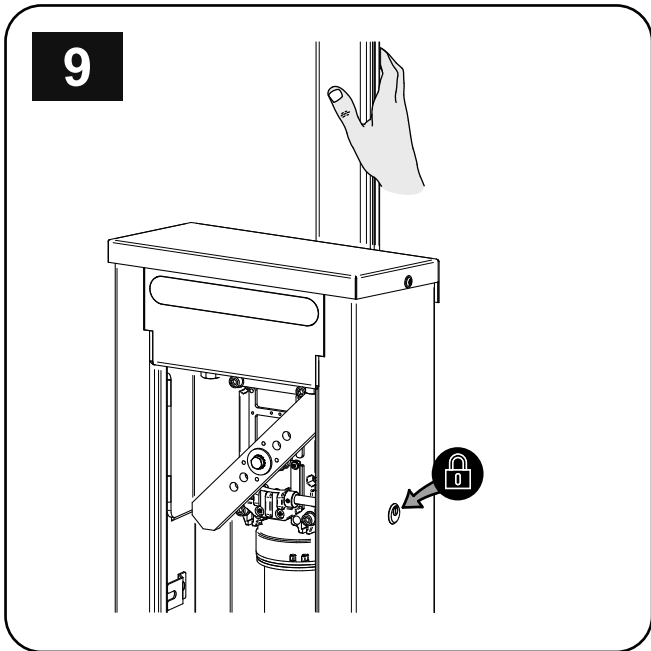

15

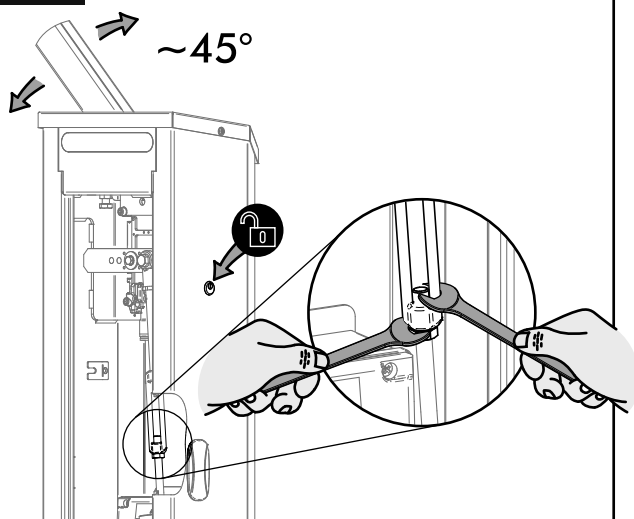

16

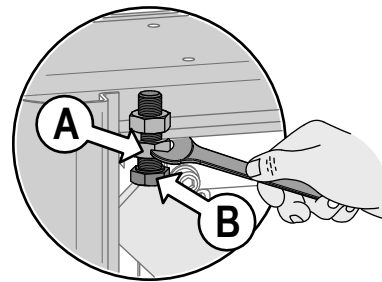

A - Dado, Nut, Ecrou,
Tuerkas, Porca,
nakrętka.

B - Fermo, Stop, Butée,
Cierres, Stop,
ogranicznik ruchu.

Regolare i fermi meccanici in modo da fornire una battuta sia chiusura che in apertura - **Adjust** the mechanical stops to supply a stroke in opening and closing - **Ajustez** la butée mécanique pour avoir une butée en ouverture et en fermeture - **Die** mechanischen Anschläge so einstellen das sie in den Endlagen auf Anschlag gehen - **Regular** los cierres mecánicos de manera de que se provee una batida en abertura y en cierre - **Ajustar** os batentes mecánicos para fornecer um batente na abertura e fecho - **Należy** wyregulować mechaniczne wyłączniki krańcowe aby zapewnić dotarcie do położenia krańcowego na otwarciu i zamknięciu

17



Tabella "BILANCIAMENTO DELL'ASTA", Table "BALANCE OF THE BOOM", Tableau "BALANCE DE LA LISSE",
 Tabla "BALANZA DE LA VARA", Tabela "BALANÇA DA HASTA", Tabell "RÓWNOWAGI PRĘTA".

Tipo di asta Boom type		Art. STRIP-LED (4-6)	Art. GSOFI	Art. 1006 / Art. 1010M	Prearico molla Spring preload (mm)	Foro usato Hole used
 DEA	3m				235	A
			X		225	A
				X	220	A
		X			230	A
		X		X	215	A
			X	X	205	A
		X	X		220	A
		X	X	X	250	A
	4m				300	A
			X		285	A
				X	282	A
		X			290	A
		X		X	280	A
			X	X	270	A
X		X		280	A	
X		X	X	265	B	
 LEGGERA LIGHT	4m				300	A
	5m				280	A





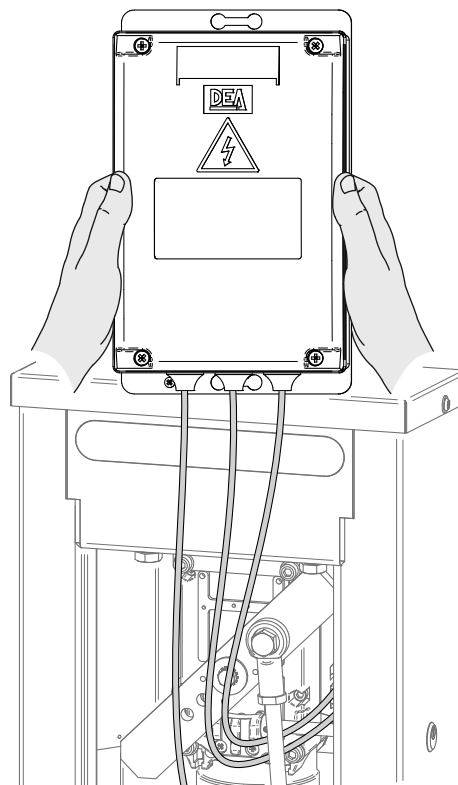
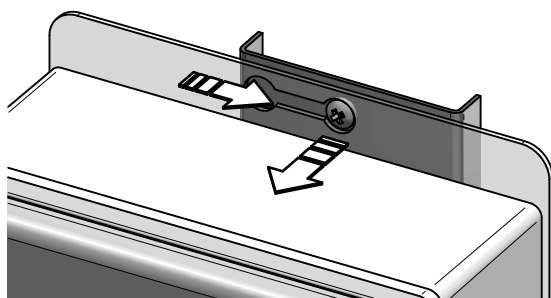
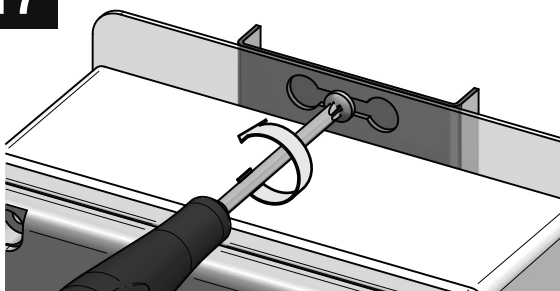
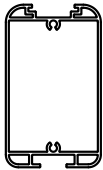
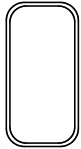





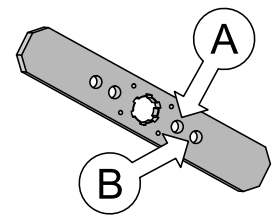
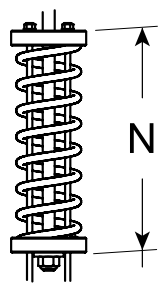

Tabella "ACCESSORI PRODOTTO", Table "PRODUCT ACCESSORIES", Tableau "ACCESSOIRES PRODUITS",
 Tabla "ACCESORIOS PRODUCTO", Tabela "ACESSÓRIOS DO PRODUTO", Tabell "AKCESORIA DODATKOWE".

Article Code	Descrizione, Description, Description, Descripción, Descrição, Opis		
BSF 649160		1 pz.	Braccetto supporto fotocellula serie Linear, Bracket for photocells range Linear, Bras support pour photocellule série Linear , Brazo de soporte por fotocélula serie Linear, Braço de suporte para fotocélula série Linear , Uchwyt fotokomórki serii Linear
Kit BSF 649161		10 pz.	
PASS N/B 649073		Base di fondazione PASS N, PASS N foundation plate, Plaque de fondation PASS N , Base de cimentación PASS N, Placa de fundação para a PASS N , Podstawa mocująca PASS N	
1006 649000		Piedino mobile, Mobile support, Support mobile , Soporte móvil, Supporte móvel , Podpórka	
1010 649020		Supporto regolabile, Adjustable fixed support, Support fixe hauteur réglable , Soporte fijo ajustable, Supporte fixo ajustável , Podpora ruchoma	
STRIP-LED 649174 + STRIP-LED/P 649173		8 mt.	Striscia LED per asta completa , LED strip for boom, Strip à LED pour lisse , Tira LED para puerta completa, Faixa de LED para haste , Listwa kompletna z diodami LED dla ramienia
GSOFTP 321810		Profilo in gomma per asta, Rubber profile for boom, Profile en caoutchouc pour lisse , Perfil de goma para vara, Perfil de borracha para haste , Profil z guma na ramię	
PASS3 649140		3 mt. DEA	Asta, Boom, Lisse , Vara, Haste , Ramię
PASS4 649141		4 mt. DEA	
PASS5 649240		5 mt. LIGHT	
OMPASS 381744		DEA	Omega di fissaggio asta , Fixing boom omega, Omega pour le fixation de la lisse , Omega de fijación de la vara, Ómega para fixação da haste , Uchwyt ramienia
OMPASS5 381745		LIGHT	
BAT/PASS N 649200		Kit per alimentazione a batterie, Kit for battery powering, Kit d'alimentation avec batterie , Kit de alimentación de batería, Kit de alimentação a baterias , Zestaw do zasilania bateryjnego	

INSTRUCTIONS FOR THE FINAL USER

This guide has been prepared for the final users of the automatism; the installer is required to deliver this guide and illustrate its contents to the person in charge of the system. The latter must then provide similar instruction to all the other users. These instructions must be carefully conserved and easily available for consultation when required.

Good preventive maintenance and frequent inspection ensures the long working life of the product. Contact the installer regularly for routine maintenance and in event of anomaly.

SAFETY RULES

1. Always keep a safe distance from the automatism during operation and never touch any moving part.
2. Prevent children from playing near the automatism.
3. Perform the control and inspection operations prescribed in the maintenance schedule and immediately stop using the automatism whenever signs of malfunction are noted.
4. Never disassemble parts of the product! All maintenance and repair operations must be performed only by qualified personnel.
5. The release operation must sometimes be performed in emergencies! All users must be instructed on the use of the release mechanism and the location of the release keys.
6. When removing the case door, there is the risk of hands sharing, in fact there are no protections when accessing the mechanics levers. Perform all operation in absence of power supply.

PASS N RELEASE MECHANISM

All PASS N models have an unlocking system; the working of this system is the following: **Disconnect power supply from the barrier.** To unlock the barrier, you just turn the lock on the side of the body (clockwise to unlock and counterclockwise to relock).

Check the release occurred, ensuring that the movement of the boom is free.

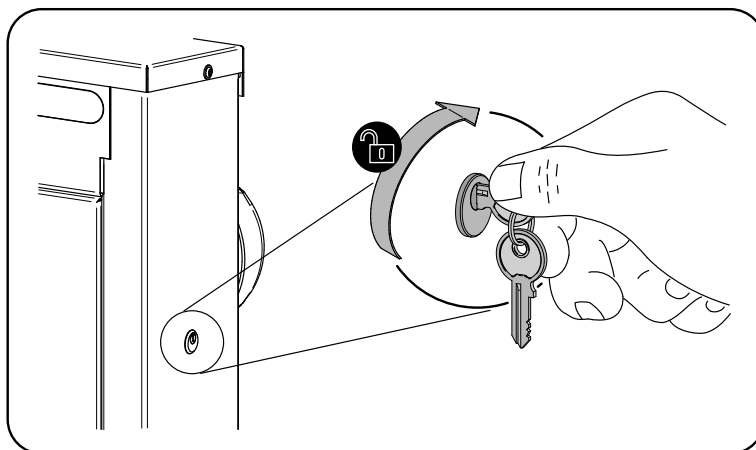

WARNING: During this operation gate may present uncontrolled movement: operate with extra care so to avoid any risk.

CLEANING AND INSPECTIONS

The only operation that the user can and must do is to remove branches, leaves, and any other object that might obstruct the gate's free movement. **Warning! Always disconnect the power supply whenever performing operations on the gate!**



EU Declaration of Conformity (DoC)

pursuant to the Machinery Directive 2006/42/CE, Att.II, A

Company name:	DEA SYSTEM S.p.A.
Postal address:	Via Della Tecnica, 6
Postcode and City:	36013 Piovene Rocchette (VI) - ITALY
Telephone number:	+39 0445 550789
E-Mail address:	deasystem@deasystem.com

declare that the DoC is issued under our sole responsibility and belongs to the following product:

Apparatus model/Product:	PASS24NET/N/V - PASS24NET/N/L - PASS24NET/N/VR
Type:	Electromechanical vehicular barrier
Batch:	See the label on the back of the user manual

The object of the declaration described above is in conformity with the relevant Union harmonisation legislation:

Directive 2006/42/CE (MD Directive)
 Directive 2014/53/EU (RED Directive)
 Directive 2011/65/EU (RoHS)

The product is in compliance with the applicable parts of the following regulations:

EN 12453:2017 - EN 60335-2-103:2015+A1:2017

The following harmonised standards and technical specifications have been applied:

Title:	Date of standard/specification
EN61000-6-2	2005 + EC:2005
EN61000-6-3	2007 + A1:2011 + EC:2012
ETSI EN 301 489-1	2019 v2.2.3
ETSI EN 301 489-3	2019 v2.1.2
EN60335-1	2012 + EC:2014 + A11:2014 + A13:2017
EN62233	2008
ETSI EN 300 220-1	2018 v3.2.1
ETSI EN 300 220-2	2018 v3.2.1
EN50581	2012

Additional information

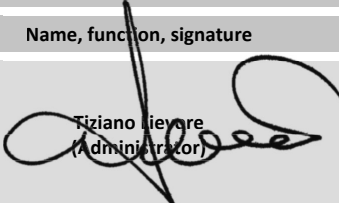
Signed for and on behalf of:		
Revision:	Place and date of issue:	Name, function, signature
00	Piovene Rocchette (VI) 02/07/2020	 Tiziano Tievare (Administrator)

